

March 11th, 2022

Dynabook Laptop Components Classified as Requiring Selective Treatment

Dynabook would like to communicate the method of identifying and removing components contained in Dynabook notebook products, including but not limited to the **Satellite Pro C40-G** model, that requires selective treatment based on the European WEEE Directive, Directive 2012/19/EU of the European Parliament and of the Council on waste electrical and electronic equipment (WEEE).

All of the instructions provided within this letter can be reviewed in greater detail within the **Satellite Pro C40-G** Series Maintenance Manual.

Tools Required

In order to remove internal components of the **Satellite Pro C40-G** some tools from the list below may be required located in **Chapter 4 Replacement Procedures** of the **Dynabook Maintenance Manual**

For your safety and the safety of the people around you, it is important that you use Electrostatic Discharge (ESD) equipment. Correctly utilizing of the equipment increases the percentage of successful repairs and saves on the cost of damaged or destroyed parts. The following equipment is required for disassembly and assembly.

- One Philips screwdriver with type 0 bit (for S-THIN HEAD screws)
- One Philips screwdriver with type 1 bit (for screws other than above)
- One flat-blade screwdriver (for removing the CPU)
- Tweezers (for lifting screws)
- ESD mats (lay on work table or floor)
- An ESD wrist strap and heel grounder
- Anti-static carpet or flooring
- Air-ionizers in highly static sensitive areas
- Antenna coaxial cable disconnecter
- Special syringe (for applying grease)

Table of Contents

- (Page 2-3) Removing the Lithium Ion Battery (Main Battery, No coin cell battery)
- (Page 4) Removing the SSD
- (Page 5-27) LCD, Printed Circuit / Wiring Boards (PCB/ PWB system board)
- (Page 28-29) AC Adapter and external provide cable

1. Removing the Lithium Ion Battery (Main Battery, No coin cell battery)

Please refer to the information below for instructions regarding the identification and removal of the lithium ion battery. Further maintenance instructions can be found in section 4.11 of the **Satellite Pro C40-G Maintenance Manual**. Some tools are required in order to remove this component. Once removed, these components should be recycled as per local requirements.

To remove the battery, the base assembly must be removed first:

Removing Base Enclosure

Remove Base Enclosure according to the following procedures and Figure 4-7.

1. Remove seven M2.0x7.0x4.5black Phillips head screws securing Base Enclosure and four M2.0x.3.5x4.5black Phillips head screws securing Base Enclosure .
2. Remove Base Enclosure..

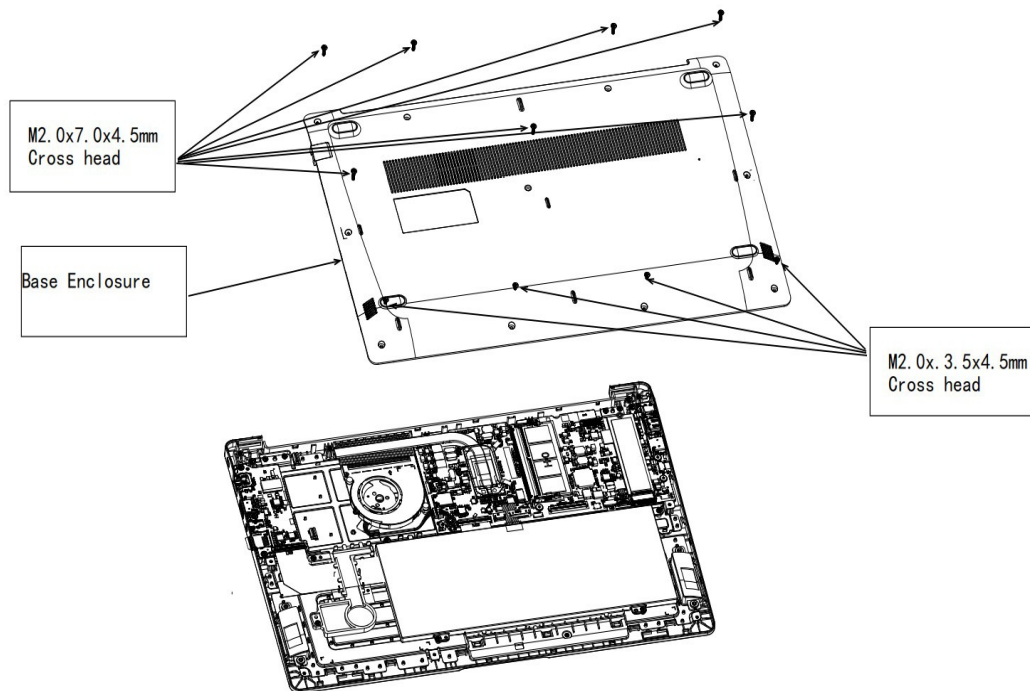

Figure 4-7 Removing Base Enclosure

Removing Battery Pack

Remove battery pack according to the following procedures and Figure 4-9.

CAUTION : When handling the battery packs, use care not to short circuit the terminals. Do not drop, hit, twist, or bend the battery packs. Do not scratch or break up their casing.

1. Remove Battery Maly.
2. Disconnect Battery cable from CN3 on system board.
3. Remove four M2.0x3.0x4.5 black Phillips head screws securing Battery.
4. Remove Battery.

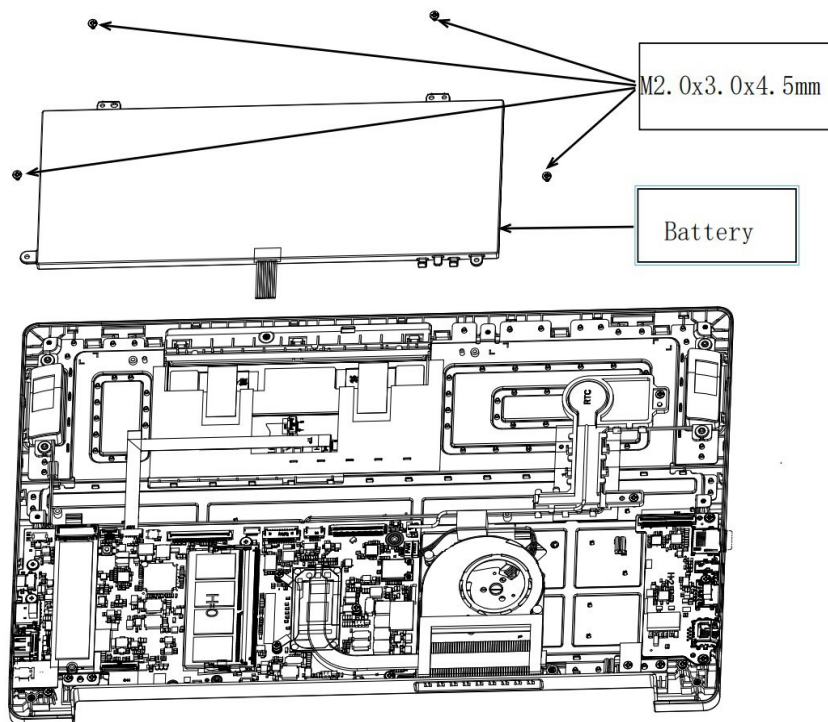

Figure 4-9 Removing battery pack

2. Removing the SSD

To remove the SSD the **mainboard** must be removed **first**.

Please refer to the information listed in section **4.8** of the **Satellite Pro C40-G Series Maintenance Manual** to check how the mainboard is removed.

Removing SSD

Remove SSD according to the following procedures and Figures 4-13.

CAUTION: Do not touch the connectors on SSD and in the computer with your bare hands. SSD can fail if they are contaminated with sweat, natural oils, etc. from your hands.

1. Remove thermally conductive pad
2. Remove one M2.0x2.5x5.0 black Phillips head screw securing the SSD.
3. Pull SSD from CN8 on system board.

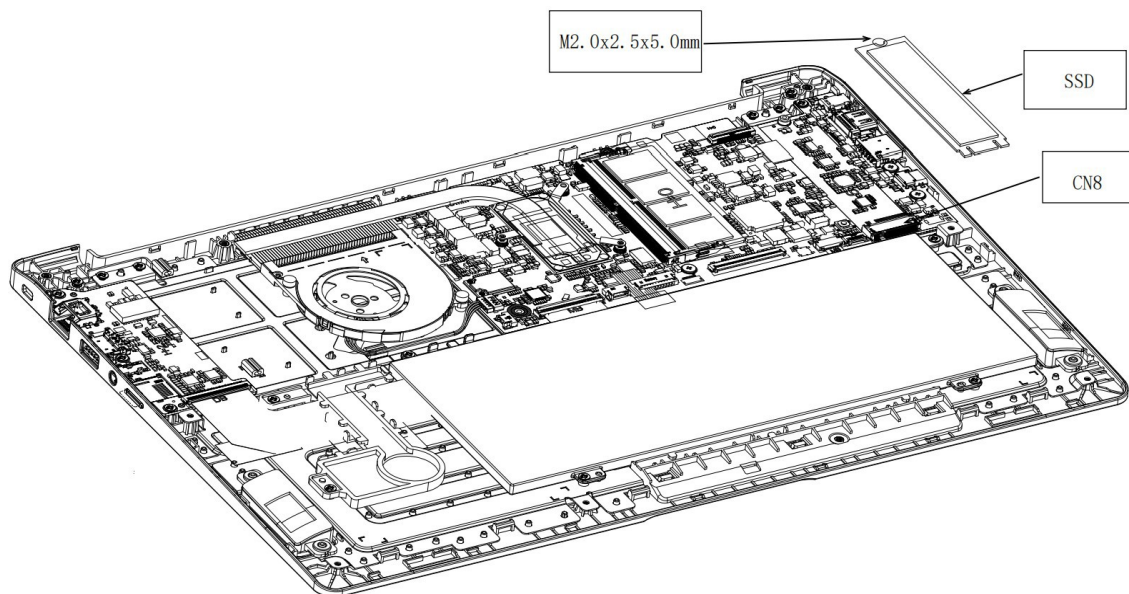

Figure 4-13 Removing SSD

3. Removing the LCD and Printed Circuit / Wiring Boards

Beside the LCD and the main PCB, there are further **small PCBs and components** which are in the scope of the WEEE Directive. The removal of these components is described in detail in the **chapter 4** of the associated maintenance manual.

Replacement Procedures

Figures

Figure 4.2 Removing Base Enclosure.....	4-7
Figure 4.3 Removing BatteryPack	4-9
Figure 4.4 Removing SSD	4-13
Figure 4.5 Removing SODIMM	4-14
Figure 4.6 Removing LCD Module A ssembly	4-17
Figure 4.7 Removing the CPU Cooling Module and Fan	4-19
Figure 4.7 Applying silicon grease(CPU).....	4-20
Figure 4.8 Removing System Board	4-21
Figure 4.9 Removing IO Board	4-23
Figure 4.10 Removing Speaker	4-25
Figure 4.11 Removing the LCD Module Mask	4-27
Figure 4.12 Removing LCD Panel follow direction	4-29
Figure 4.12 Removing the LCD cable	4-32
Figure 4.12 LCD cable below the LCD module cover latch	4-32
Figure 4.13 Removing the CCD Module	4-33
Figure 4.14 Removing the Touch pad Module	4-35

4.2 Base Enclosure

Removing Base Enclosure

Remove Base Enclosure according to the following procedures and Figure 4-7.

1. Remove seven M2.0x7.0x4.5black Phillips head screws securing Base Enclosure and four M2.0x3.5x4.5black Phillips head screws securing Base Enclosure .
2. Remove Base Enclosure..

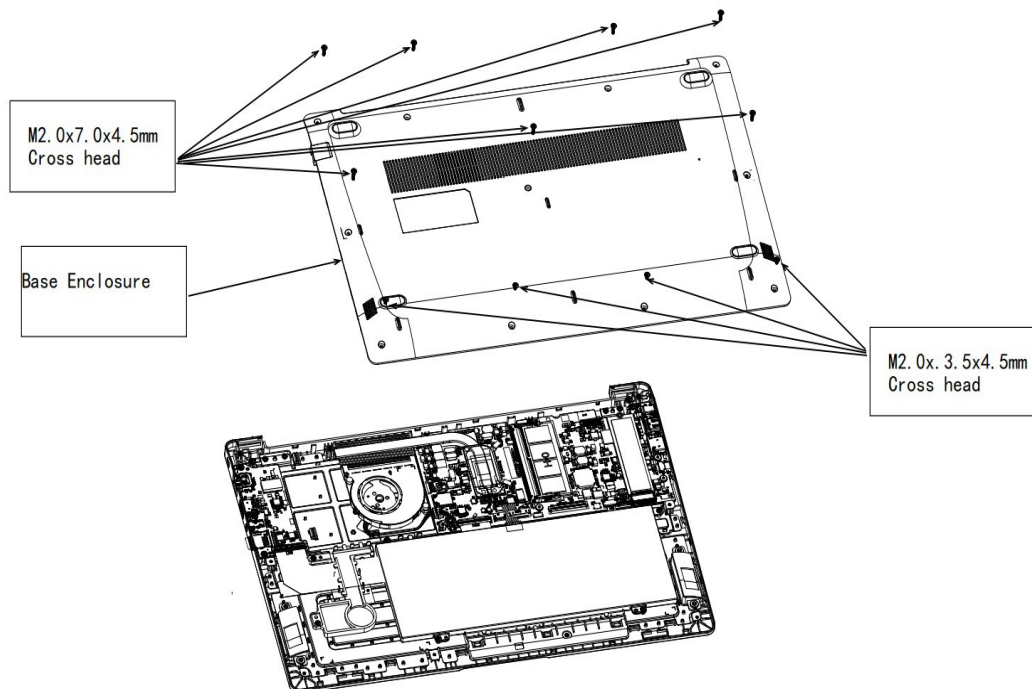

Figure 4-7 Removing Base Enclosure

Installing Base Enclosure

Install Base Enclosure according to the following procedures and Figure 4-7.

1. Place Base Enclosure in correct position.
2. Secure Base Enclosure with seven M2.0x7.0x4.5black Phillips head screws and M2.0x3.5x4.5black Phillips head screws .

4.3 Battery Pack

Removing Battery Pack

Remove battery pack according to the following procedures and Figure 4-9.

CAUTION : When handling the battery packs, use care not to short circuit the terminals. Do not drop, hit, twist, or bend the battery packs. Do not scratch or break up their casing.

1. Remove Battery Maly.
2. Disconnect Battery cable from CN3 on system board.
3. Remove four M2.0x3.0x4.5 black Phillips head screws securing Battery.
4. Remove Battery.

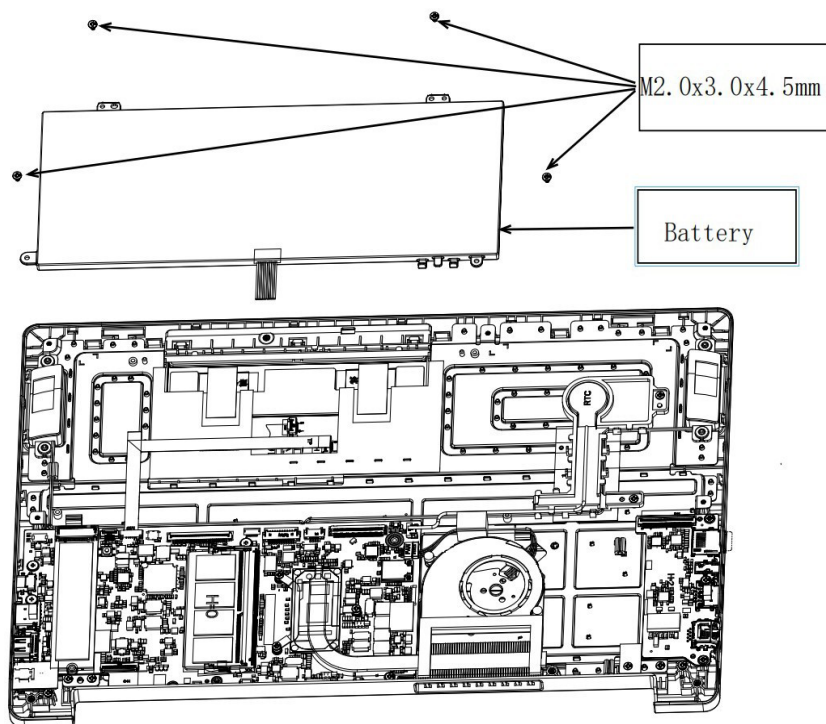

Figure 4-9 Removing battery pack

NOTE: Dispose of the used battery packs as required by local ordinances or regulations.

Installing Battery Pack

Install battery pack according to the following procedures and Figure 4-9.

CAUTION : The battery packs contain a lithium ion battery, which can explode due to improper replacement, use, handling, or disposal. Always dispose of the battery packs as required by local ordinances or regulations. Use only replacement batteries recommended by Toshiba.

NOTE: Visually check the battery's terminals. If they are dirty, clean them with a dry cloth.

1. Take a new or recharged Battery Pack.
2. Place Battery Pack in correct position.
3. Secure Battery with four M2.0x3.0x4.5 black Phillips head screws.
4. Check the battery screw hole ,if there is cracking, please replace the parts.
5. Connect Battery cable to CN3 on system board.
6. Installing Battery Maly.

4.4 SSD

Removing SSD

Remove SSD according to the following procedures and Figures 4-13.

CAUTION: Do not touch the connectors on SSD and in the computer with your bare hands. SSD can fail if they are contaminated with sweat, natural oils, etc. from your hands.

1. Remove thermally conductive pad
2. Remove one M2.0x2.5x5.0 black Phillips head screw securing the SSD.
3. Pull SSD from CN8 on system board.

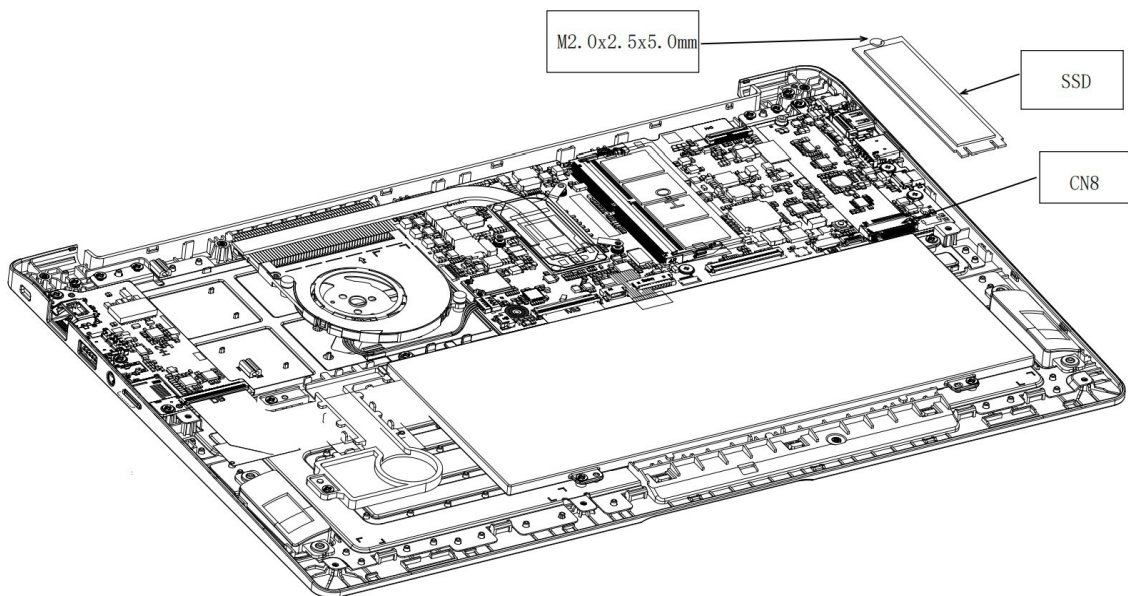

Figure 4-13 Removing SSD

Installing SSD

Install SSD according to the following procedures and Figures 4-13.

1. Insert SSD into CN8 on system board.
2. Secure it with one M2.0x2.5x5.0 black Phillips head screw.
3. Install thermal sillicage!

CAUTION: Do not touch the connectors on SSD and in the computer with your bare hands. SSD can fail if they are contaminated with sweat, natural oils, etc. from your hand

4.5 SODIMM Removing

SODIMM

Remove SODIMM according to the following procedures and Figures 4-14.

CAUTION: Do not touch the connectors on SODIMM and in the computer with your bare hands. SODIMM can fail if they are contaminated with sweat, natural oils, etc. from your hands.

1. Press both sides of the J1 connector shrapnel 15° with both index fingers
2. Take out the SODIMM at 45° horizontal

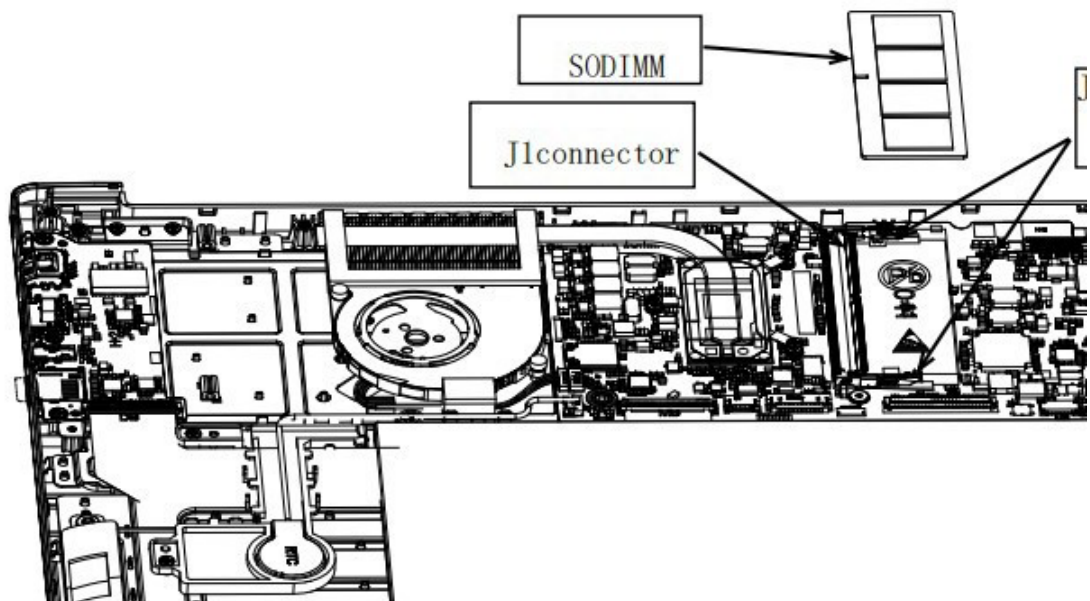

Figure 4-14 Removing SODIMM

Installing SODIMM

Install SODIMM according to the following procedures and Figures 4-14.

1. Aim the SODIMM at the J1 slot
2. Lightly press the SODIMM upper and lower sides with two fingers

CAUTION: Do not touch the connectors on SODIMM and in the computer with your bare hands. S O D I M M can fail if they are contaminated with sweat, natural oils, etc. from your hands

4.6 LCD Module Assembly

NOTE: Touch SKU will provide the FRU parts as LCD Module Assembly.

Removing LCD Module Assembly

Remove LCD Module Assembly according to the following procedures and Figure 4-17.

1. Remove tape for fasten LCD cable.
2. Remove PC gasket from WIFI module Remove plastic chips on wifi module.
3. Disconnect LCD cable from CN6 on system board.
4. Released wireless antenna cables from top cover latch.
5. Open LCD Module Assembly at an angle of 90 degrees.
6. Remove six M2.0x5.5x4.5 black Phillips head screws securing LCD Module Assembly with top cover.
7. Remove LCD Module Assembly.

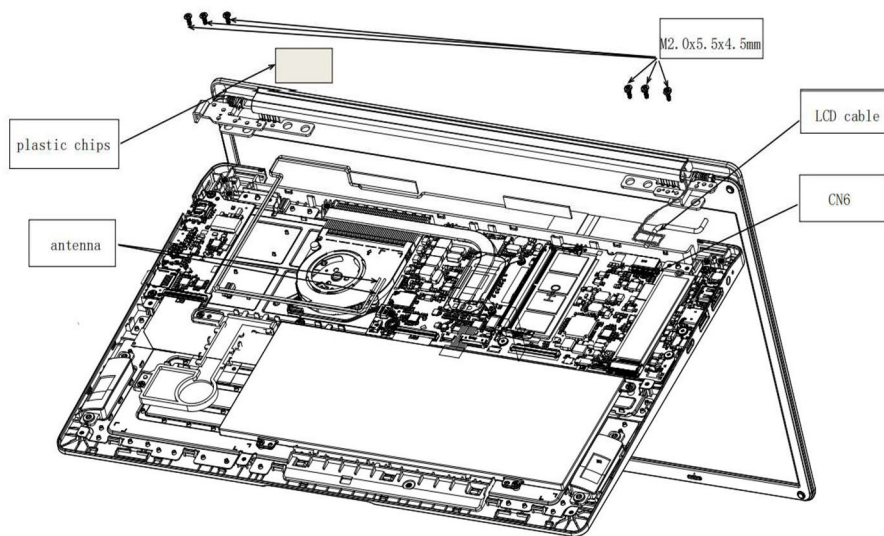

Figure 4-17 Removing the LCD Module assembly



Figure 4-18 Removing the LCD Module assembly

Installing the LCD Module Assembly

Install the LCD Module Assembly according to the following procedures and Figure 4-17 and 4-18.

1. Place the LCD Module Assembly in the correct position.
2. Secure LCD Module Assembly with four M2.0x5.5x4.5 black Phillips head screws.

(▲ mark portions)

3. Close LCD Module Assembly.
4. Note the module definition :grey wire connects MAIN interface and black wire connects AUX
5. Routing antenna cables under Rib on Top cover to secure antenna cables according to Figure 4-18.
6. Put the PC gasket back on the WiFi module Install plastic chips on wifi module.
7. Connect LCD cable to CN6 on system board.
8. Routing LCD cable according to Figure 4-18, need to under Rib on Top Cover.
9. Stick tape to fasten LCD cable.

4.7 CPU Cooling Module and Fan

CAUTION: When removing CPU Cooling Module and Fan, keep following in mind:
The CPU Cooling Module can become very hot during operation. Be sure to let it cool down before starting the repair work. Hold Fan on its outline, do not press on its center.
Do not touch or cause damage to the fan in the CPU Cooling Module.

Remove CPU Cooling Module and Fan VGA SKU only

Remove CPU Cooling Module and Fan according to the following procedures and Figures 4-19 and 4-20.

1. Remove cushion for FAN.
2. Remove four M2.0x3.0x4.5 black Phillips head screws securing CPU Cooling Module.
3. Remove CPU Cooling Module.
4. Disconnect Fan cable from CN21 on system board.
5. Remove the plastic pad from the fan screw. Remove the plastic pad from the fan screw.
6. Remove two M2.0x3.0x4.5 black Phillips head screws securing Fan.
7. Remove FAN.

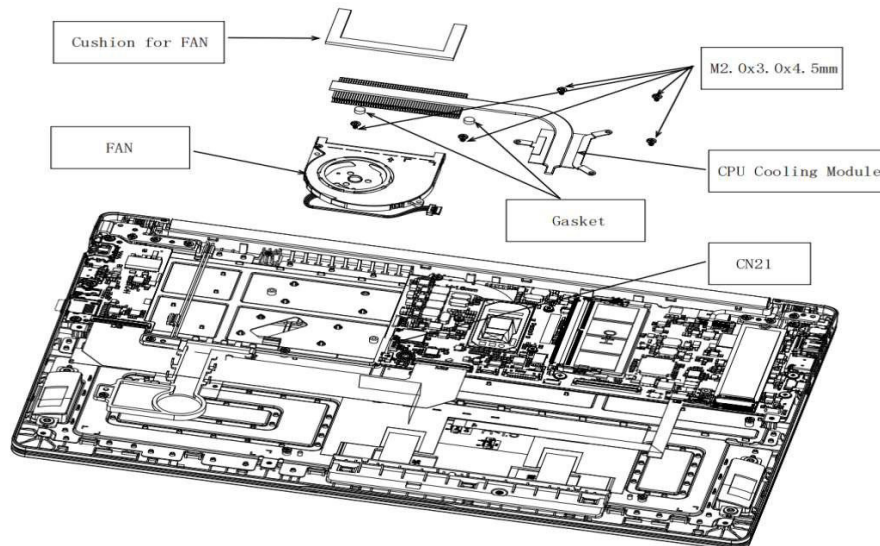



Figure 4-20 Applying silicon grease

4.8 System Board

Removing System Board

Remove System Board according to the following procedures and Figures 4-21.

1. Disconnect the following cable from the connector on System Board: -
 - Speaker cable from SPK.
 - LCD cable from CN6.
 - IO Board cable from CON19
 - Touch Pad cable from TPCON1.
 - Keyboard cable from KBCON1.
 - FAN cable from CN21.
 - Battery Pack cable from CN3.
 - RTC Battery from RTCCN1.
 - Released wireless antenna cables from top cover latch.
2. Remove two M2.0x3.0x4.5 and three M2.0x2.5x5.0 black Phillips head screw securing System Board.
3. Remove System Board.
4. Remove the high position adhesive paper of DC seat

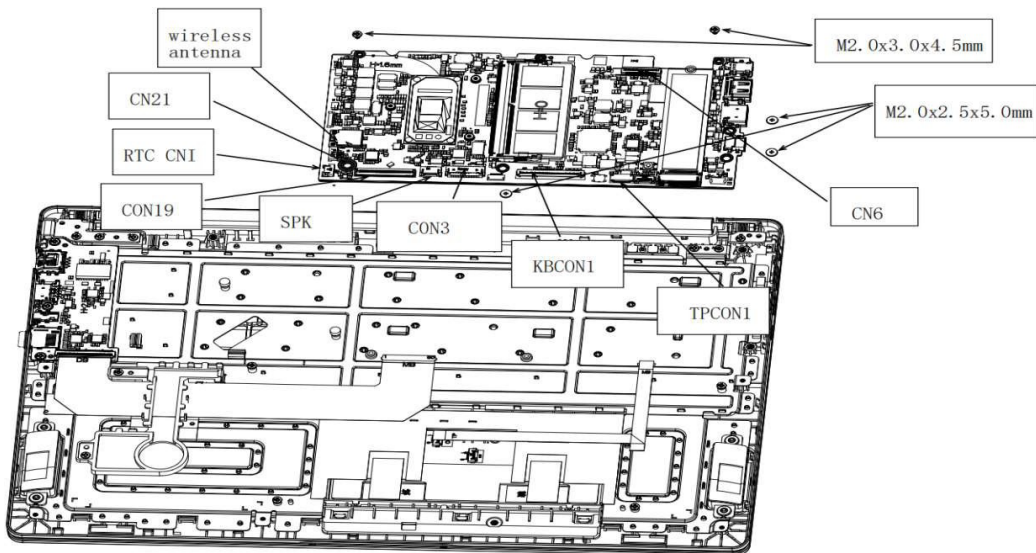

Install System Board according to the following procedures and Figures 4-21.

1. Place System Board in correct position.

2. Securing System Board with two M2.0x3.0x4.5 and three M2.0x2.5x5.0 black Phillips head screw.

(▲ mark portions)

3. Connect following cable to the connector on System Board:

- Speaker cable from SPK.
 - LCD cable from CN6.
 - IO Board cable from CON19
 - FFC-MB terminal connected to TP-CON1
 - keyboard connection KBCON1, over the speaker wire wiring. -
 - FAN cable from CN21.
 - Battery Pack cable from CN3.
 - RTC Battery from RTCCN1.
 - Released wireless antenna cables from top cover latch. -
- Place System Board in correct position
- DC block paste high temperature adhesive paper

NOTE:

Be sure to place all cables into the ditch to avoid the damage during assembling the bottom cover.

NOTE:

Be sure to align Type-C connector to Top Cover, when place system board on the unit..

4.9 IO Board

Removing IO Board

Remove IO Board according to the following procedures and Figures 4-23.

1. Disconnect the following cable from the connector on IO Board: -
IO Board cable from JDB1
2. Remove three M2.0x3.0x4.5 black Phillips head screw securing IO Board.
3. Remove the IO panel Myla.

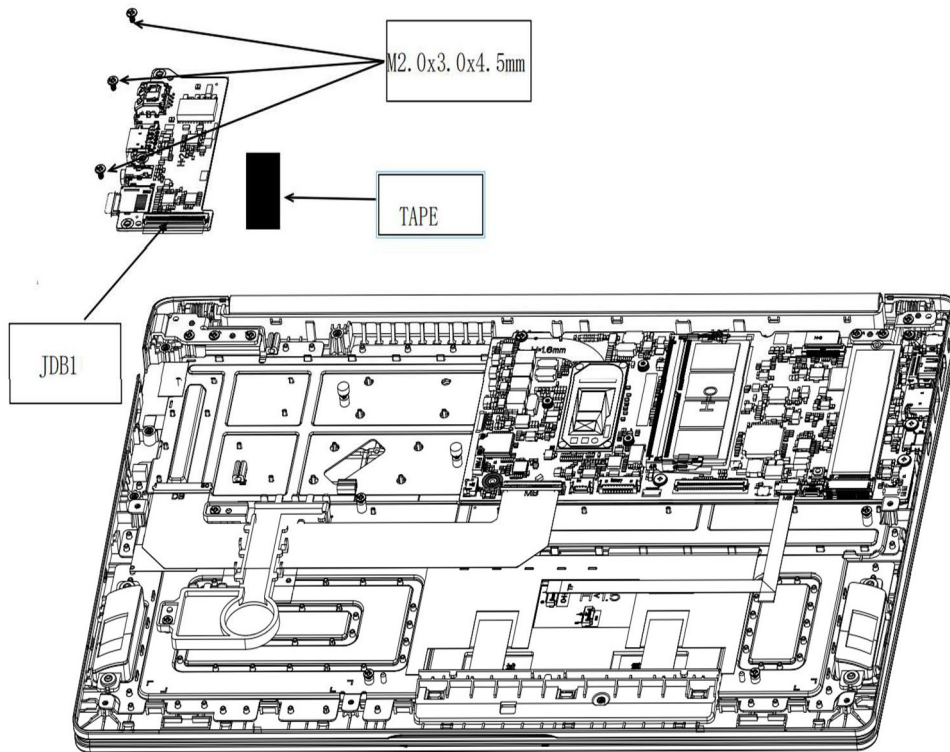

Figure 4-23 Removing IO Board

Install IO Board according to the following procedures and Figures 4-23.

1. Place IO Board in correct position.
2. Securing IO Board with three M2.0x3.0x4.5 black Phillips head screw.
3. Connect following cable to the connector on System Board:
 - IO Board cable from JDB1
4. Stick tape on the IO Board.

4.10 Speaker

Removing Speaker

Remove Speaker according to the following procedures and Figure 4-25.

1. Disconnect Speaker cable from SPK on system board.
2. Remove left and right Speaker.

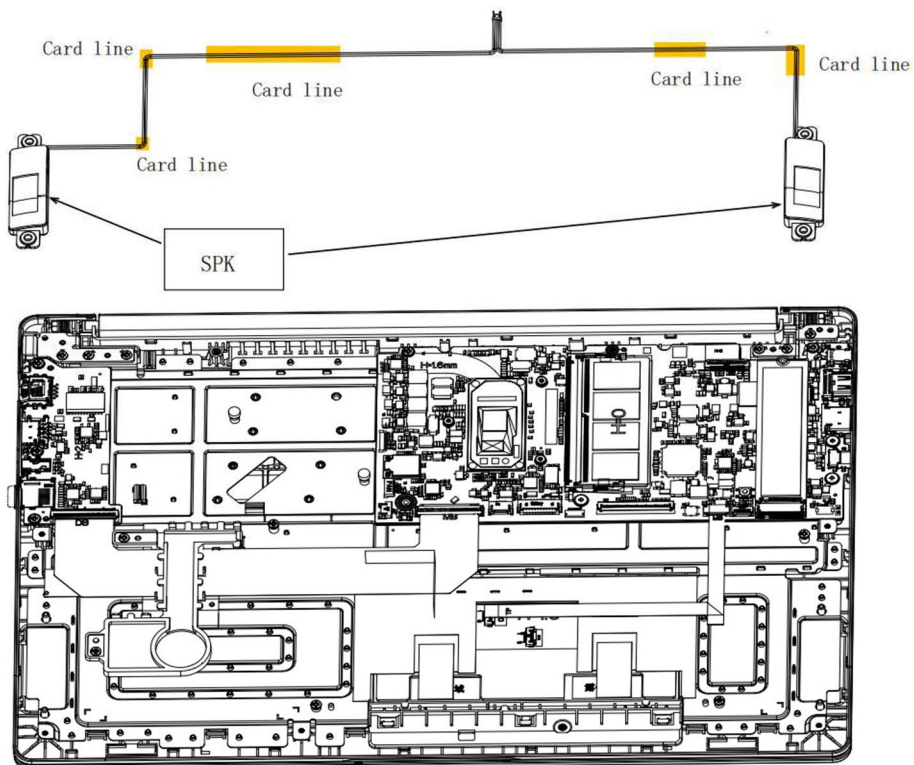

Figure 4-25 Removing Speaker

Installing Speaker

Install Speaker according to the following procedures and Figure 4-25.

1. Place speaker in correct position.
2. Connect speaker cable to SPK on system board

4.11 LCD Module Mask

NOTE: This chapter is only for Non-Touch SKU. We provide Touch Panel Assembly for Touch SKU.

Remove the LCD Module Mask

Removing the LCD Module Mask according to the following procedures and Figure 4-11 & 4-12.

1. Remove four Black (Remove the four rubber footpads from the B shell)
2. Remove four M2.0x3.0x4.5 black Phillips head screws securing the LCD Module Mask as Figure 4-11 shown .
3. Insert your finger between the edge of LCD Module Mask and the LCD panel by twist in correct indication and follow step 1, 2 & 3 to release the latches as Figure 4- 27 shown.
4. Remove the LCD Module Mask while unlatching the LCD Module Mask.

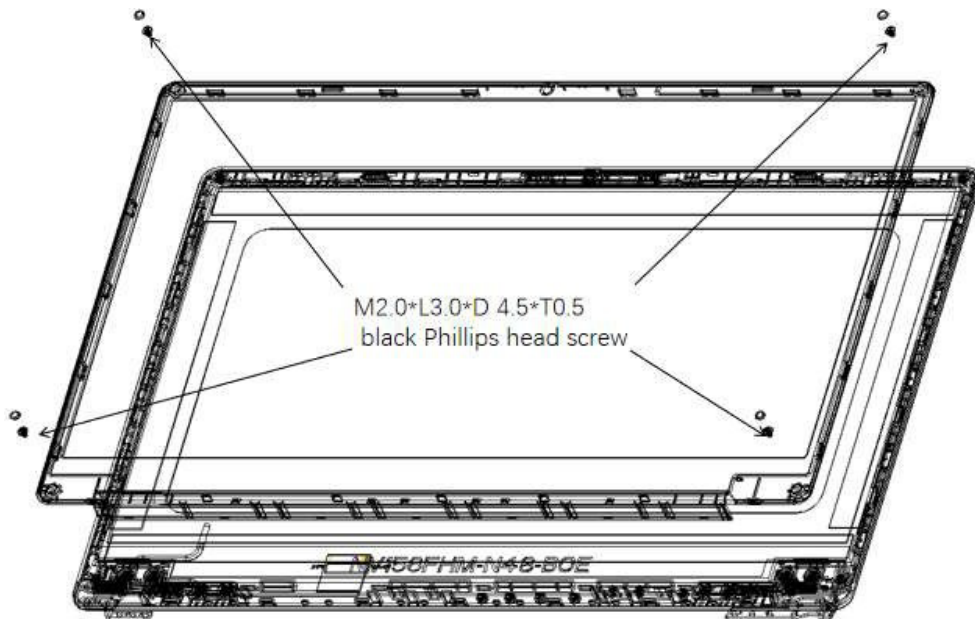

Figure 4-27 Removing the LCD Module Mask

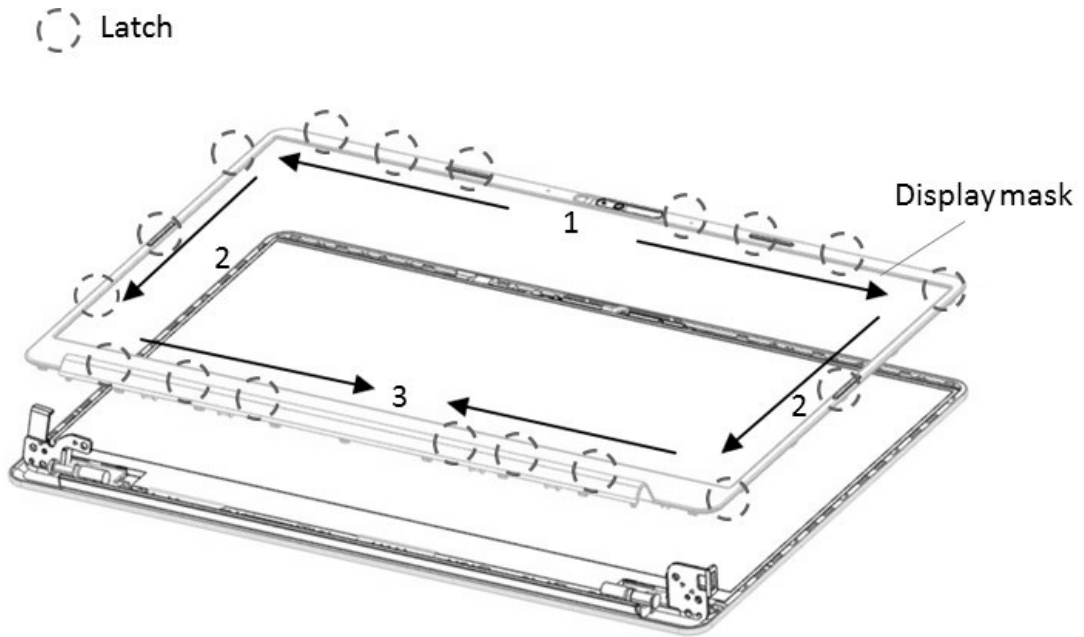

Figure 4-28 Removing the LCD Module Mask

Installing the LCD Module Mask

Install the LCD Module Mask according to the following procedures and Figure 4-27 & 4-28.

1. Install the LCD Module Mask and follow step 3, 2 & 1 to press & lock the latches.
2. Securing the LCD Module Mask with four M2.0x3.0x4.5 black Phillips head screw.
3. Install 4 rubber foot pads Install four plastic pads.

NOTE: When installing the LCD Module Mask, ensure there is no gap between the LCD Module Mask and the LCD module cover.

NOTE: Do not lose the Camera Shutter.

4.12 LCD Panel

NOTE: Touch SKU will provide the FRU parts as LCD Module Assembly.

This chapter only for Non-Touch SKU.

NOTE: ICs are fragile. Use extreme care not to apply pressure to the ICs along the edges of the LCD module.

NOTE: Dispose of used LCD Panel (fluorescent (FL) tubes) as required by local ordinances or regulations.

NOTE: The LCD cable must be carefully peeled away before disconnecting it from the module.

Removing the LCD Panel

Remove the LCD Panel according to the following procedures and Figures 4-29 & 4-30.

1. Follow the Figure 4-29 direction 1 to lift up LCD panel.
2. Carefully tilt the LCD module toward you.
3. Turn the LCD upside down. Be sure to place it on a cushioned surface such as a foam pad.
4. Remove the tape and LCD cable connector. Then disconnect the LCD cable as Figure 4-30 shown.

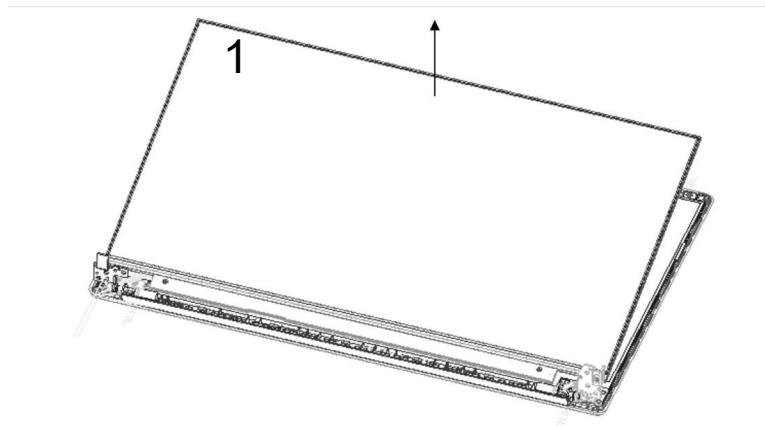

Figure 4-29 Removing LCD Panel follow direction 1.

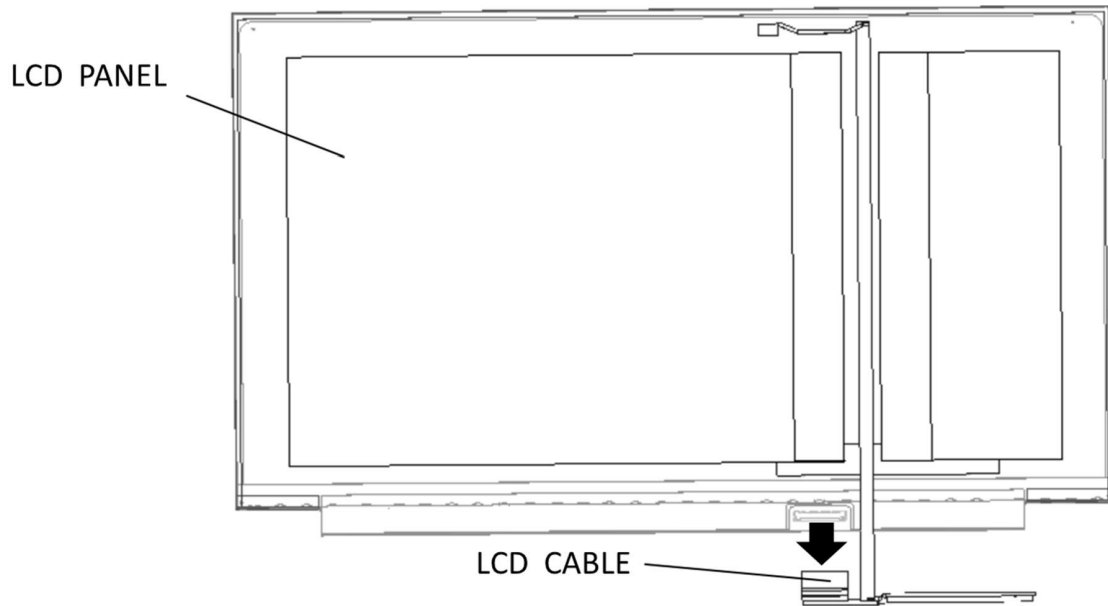

Figure 4-30 removing the LCD cable

Installing the LCD Panel

NOTE: LCD/FL cable must be carefully peeled away before disconnecting it from the module.

Install the LCD Panel according to the following procedures and Figures 4-29 and 4-30

Installing the LCD panel

Install the LCD Panel according to the following procedures.

1. Turn the LCD upside down.
2. Connect the LCD cable to the LCD module connector as Figure 4-30-1 shown.
3. Lift LCD panel top side up as Figure 4-30 shown and bottom side down on the LCD module cover.
4. Then place the LCD panel. Check LCD cable below the LCD module cover latch as Figure 4-30 shown.

CAUTION: When installing the LCD module, please follow below instruction:
When plug in LCD/FL cable into LCD panel connector, need to plug horizontally.

4.13 CCD Module

NOTE: Touch SKU will provide the FRU parts as LCD Module Assembly. This chapter only for Non-Touch SKU.

Removing the CCD Module

Remove the CCD Module according to the following procedures and Figure 4-33

1. Lift the CCD Module from the LCD module cover.
2. Disconnect LCD cable from CCD Module connector.

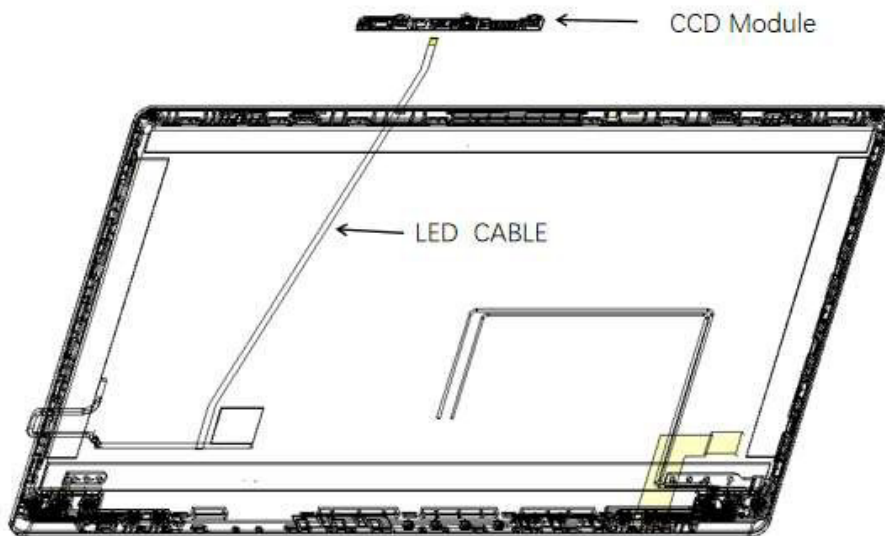

Figure 4-33 Removing the CCD Module

Installing the CCD Module

Install the CCD Module according to the following procedures and Figure 4-33.

1. Remove CCD Module release paper.
2. Connect LCD cable to CCD module connector.
3. After ripping off FPC release paste FPC into shell LCD cover.
4. Seat the CCD Module in the correct position.
5. Route the LCD cables according to Figure 4-29, place the cable into the ditch and correct position. Avoid to pinching the cables.

4.14 Touch pad

Removing Touch pad

Remove Touch pad according to the following procedures and Figures 4-35.

CAUTION: Do not touch the connectors on Touch pad and in the computer with your bare hands. Touch pad can fail if they are contaminated with sweat, natural oils, etc. from your hands.

1. Separate the touchpad from the C shell
2. Detach the bracket from the trackpad

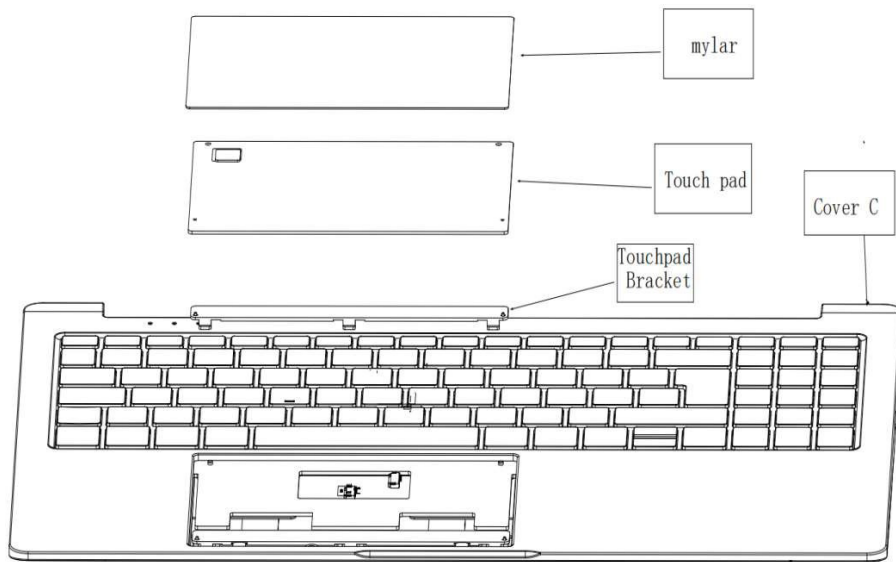

Figure 4-35 Removing Touch pad

Installing Touch pad

Install Touch pad according to the following procedures and Figures 4-35.

1. Tear off 3MM adhesive release paper
2. Paste the touchpad holder
3. Tear off fingerprint high temperature tape
4. Tilt the touchpad to 45°, put the bottom into the C shell, paste and press
5. Remove the mylar release paper and paste the adhesive

CAUTION: Do not touch the connectors on Touch pad and in the computer with your bare hands. Touch pad can fail if they are contaminated with sweat, natural oils, etc. from your hands

AC Adapter, External cables provided with the AC adapter and USB cables

The AC adapter as well as all external cables provided with the notebook including the AC adapter cables and USB cables should be segregated and sent for shredding.

The following components contained within the AC adapter potentially contain hazardous substances and require special handling:

- Printed Circuit Board >10 cm²
- Capacitor >25 mm in height

Photos of the AC adapter and the components noted above are included below.
The notebook has one of two types of AC adapter.

USB connection type



AC adapter

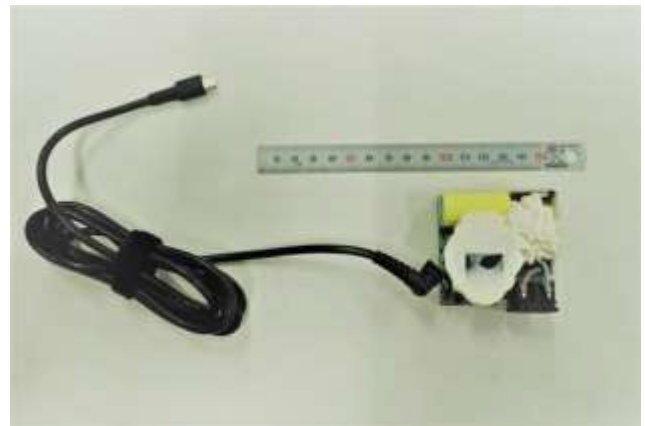

AC Adapter with casing removed



AC Adapter printed circuit board



AC adapter capacitor

Conventional type



AC adapter

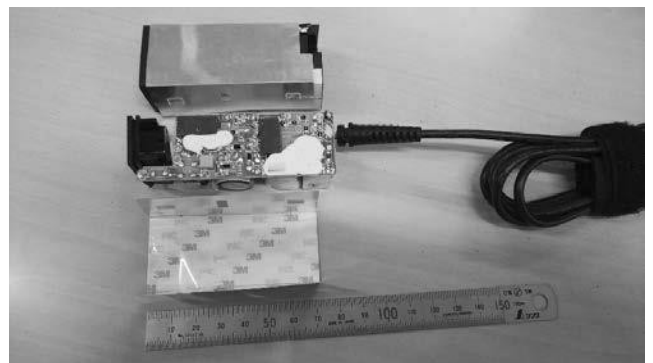

AC Adapter with casing removed

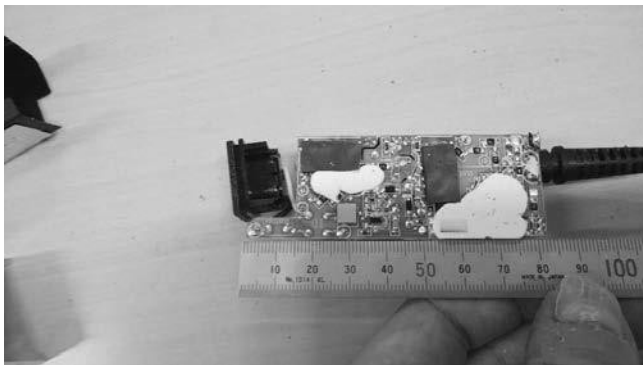

AC adapter printed circuit board

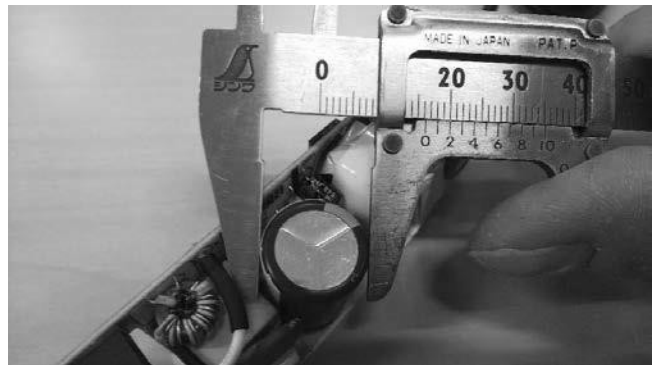

AC adapter capacitor